

General installation and placement requirements for DELTA-O

The following installation guidelines and examples for DELTA-O concealed drains were drawn up for general applications. Special installation situations based on local data should always be assessed case by case. The technical guidelines and good workmanship that apply in the field should be observed when placing and installing the drains.

The installation position of the drains, the type of paving and the traffic that will drive over the drains should be taken into account. The different load classes have been determined in accordance with the **European standard EN 1433**.

Installation shall occur in accordance with the guidelines that you receive together with the delivery. A risk analysis must be carried out before the drains are installed to identify any possible hazards and risks so that the right control measures can be taken on time.

DELTA-O concealed drains type I

DELTA-O concealed drains are produced and delivered in accordance with the harmonised European standard EN1433, under which they are type I, i.e. they require no further support. Loads may be placed on the drains up to the load classes for which they are produced:

- EN1433 Group 1: A15. Zones used only by pedestrians and cyclists.
- EN1433 Group 2: B125. Pavement, pedestrian zones and similar zones, multi-storey car parks.
- EN1433 Group 3: C250. For drains that are placed in the zone of the gutter along the pavement and that measured from the kerb of the pavement, are placed no more than 0.5 metres into the road and no more than 0.2 metres into the pavement.
- EN1433 Group 4: D400. Public roads with dynamic loads of freight and passenger transport.
- EN1433 Group 5: E600. Traffic zones with heavy wheel loads and intensive, heavy traffic such as industrial estates and ports with loading and unloading docks.
- EN1433 Group 6: F900. Infrastructure at airports and container terminals with particularly heavy wheel loads.

Unloading, storage and placement

The DELTA-O concealed drains must be unloaded and placed using approved lifting gear. We recommend using lifting keys that have been made specially for unloading and placing DELTA-O concealed drains that are available from your supplier. The drains must be unloaded and placed with due care and in accordance with sound engineering practice.

1. Place the lifting key in the slot of the drain element.
2. Turn it 90 degrees.
3. Make sure the lifting key cannot turn during lifting.
4. Secure the lifting keys with a bar through the specially provided eyes.

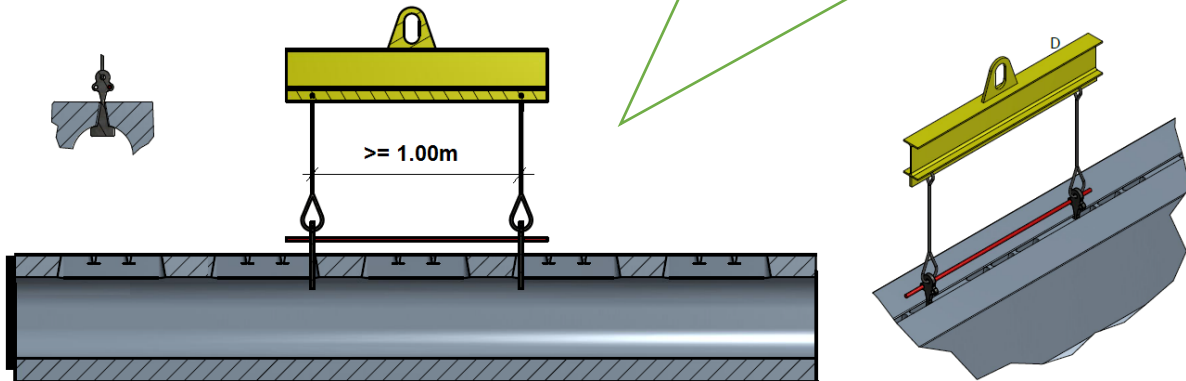

PLEASE NOTE:

- X: Never lift the drain elements by the bridges in the slots of the drain.
- X: Never lift the sand traps by the steel or cast-iron grate, frame or profile.

Foundation and bedding

The bedding must be created at the same slope as the prescribed slope for the drains. The supporting surface must be smooth and even to ensure that pressure is distributed uniformly. If the underground is suitable, the ground surface may be used as the supporting surface.

To smooth out any unevenness, a layer of sand can be applied on top. If the underground is not suitable, blinding can be opted for, consisting of either consolidated and compacted material or lean concrete. If the engineering firm determines that the drains must be installed on a **cured concrete foundation**, the drains will be placed on a **mortar bed** (see point 3 in the schematic diagram below).

The drains are laid from downstream to upstream. At the end with a seal that faces upstream, a trench of at least 2x2 cm must be made in the bedding. This serves as an expansion joint at the connection between the two drain elements. After that, place the new drain element straight and evenly against the end of the drain element with a seal already in place. We apply a joint width of 15 mm. Corrections by pressing, pushing or tapping with the bucket of a crane are not permitted.

PLEASE NOTE: **Bends** are created using DELTA-O concealed drains with an integrated bend (please contact your supplier for more information).

Contiguous traffic areas

Load transfer from contiguous traffic areas is not permitted. Make sure that the expansion joints are wide enough along the length of the drains (always the case if there is continuous, contiguous concrete paving) (see point 2). Expansion joints in the contiguous surface perpendicular to the drain line must be designed in such a way that they connect with the end joint of the drain connection.

When the contiguous road surface or paving has been laid and completed, the expansion joint must be sealed with a suitable, flexible jointing compound. Use the product guide and instruction manual of the supplier of the jointing compound.

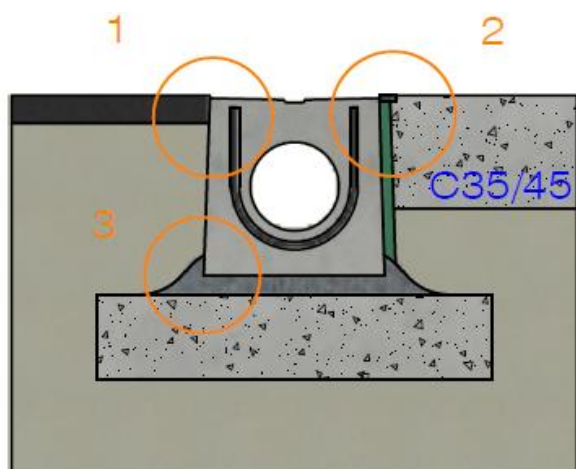

To prevent bits of concrete from breaking off (for example as a result of settlement or thermal expansion), the joints must be sealed in such a way that there is no rigid and hardening connection between the drain elements (lateral joint) and/or the contiguous paving (longitudinal joint). Mortar or concrete may not be used to fill the joints.

In the final situation (before delivery), the contiguous paving must permanently be 3-5 mm higher than the top of the drain element including its cover, in order to guarantee that water drains off and also avoid any mechanical damage (e.g.

street-cleaning vehicles, snow ploughs, vibratory plates) (see point 1).

The same installation guidelines and placement requirements as above apply for the complimentary concrete elements such as sand traps and outlets for example, that are placed in line with the drain elements.

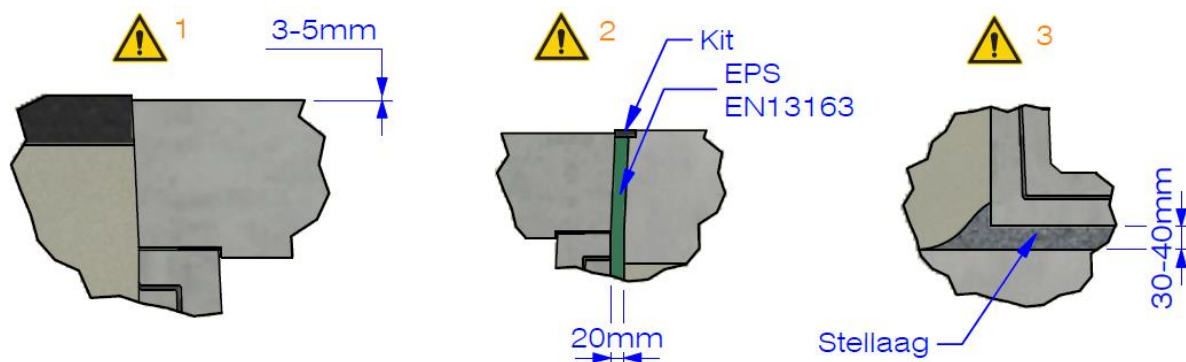

The client explicitly acknowledges that if these guidelines are not applied in part or at all, the supplier and manufacturer shall be relieved of any liability and any ensuing damage cannot be recovered.